

The Start

1938 - Hewlett – Packard

The story of Mass Spectrometry at Agilent Technologies starts with the founding of Hewlett-Packard in 1938 by two class of 1934 Stanford graduates Bill Hewlett and David Packard. They started the business part time in the garage at 367 Addison Avenue Palo Alto. This site was officially designated as a California State Historical Landmark in 1987, and is the birthplace of HP, Agilent and a leading Silicon Valley milestone. In 1999 Agilent became the biggest IPO of the time in Silicon Valley.



The garage at 367 Addison Avenue

1965 - Analytical Instrumentation

It was not until the acquisition of F&M Scientific in 1965 that HP entered the analytical instrumentation field, which would lead to the development of the first mass spectrometer from HP, and a continuing 48 year history of developments in MS technology.

First Mass Spectrometers

1971 - 5930A GC/MS System

The first mass spectrometer introduced was the 5930A GC/MS system, which included an integrated oscilloscope for tuning and a strip chart recorder. The MS featured a dodecapole arrangement and offered a mass range upto m/z 650.

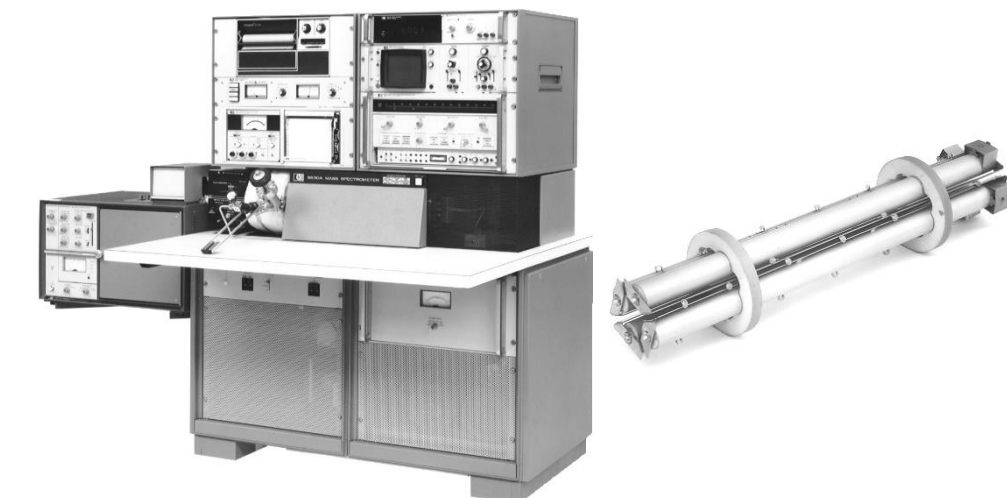

5930A GC/MS and dodecapole assembly.

1974 - 5980 Series GC/MS System

The 5980 system implemented the use of a new technology for the first time – mini-computers, and became the basis of a family of floor standing units.

5992A Benchtop GC/MS System -1976

The introduction of the 5992 was a milestone in GC/MS systems, being the first truly benchtop GC/MS system. The GC and MS were totally integrated into one unit with the quadrupole sitting inside of a diffusion pump! Instrument control was by an early desktop computer and thermal printer.

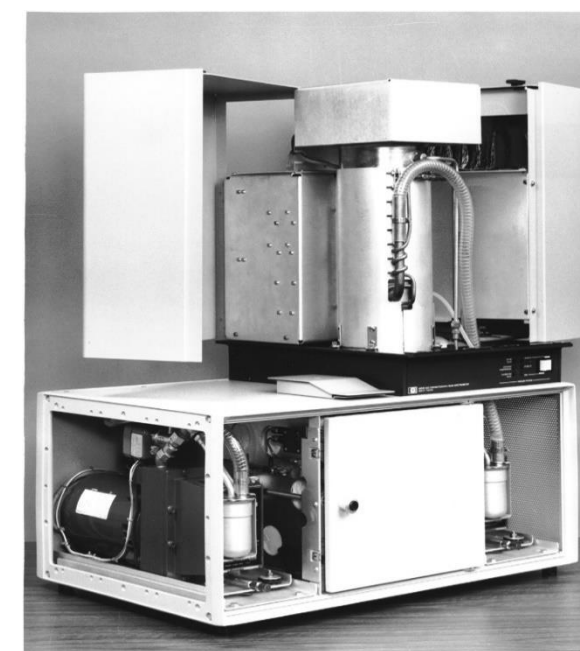

5992A Benchtop GC/MS.

Taking MS to the Masses

1977 – 1992 Floor Standing Systems Evolution

Shortly after the introduction of the 5992A benchtop GC/MS system in 1977 the 5985 floor standing model gave the user greater flexibility and performance with an easily interchangeable EI / CI Ion source, and the ability to split to multiple detectors. This was followed by the implementation of new technologies such as Thermospray and Particle beam ionization to allow the use of liquid introduction (the first LC/MS capable systems) along with continued improvements to the computer control. This led to a highly flexible and capable unit by the time of the last of the floor standing units in 1992, the 5989 model.



5989 MS "Engine" System

1982 – The first "MSD"

After several enhancements to the 5992A unit, a change in concept for benchtop GC/MS was proposed by Ned Kuypers to make a MS that became a GC detector and coupled to the recently introduced HP 5791A GC. This "memo" led to the development and release of the 5970A in 1982 – the first of the mass selective detector "MSD" family of systems.

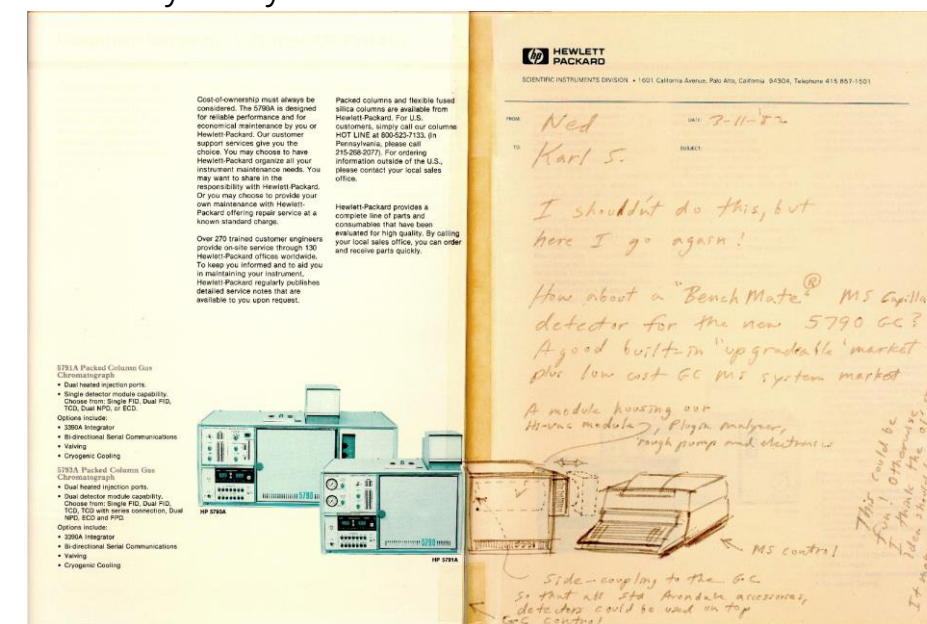

Original memo that led to 5970 MSD

1984 – 1996 GC/MSD for all.

Development of the MSD concept continued, with important advances in instrument control with new PC technologies and software to make the systems easier to use for a greater group of scientists. 1990 saw the introduction of a whole new model, the 5971, which featured a glass hyperbolic quadrupole, removing the need for precision alignment providing reliable mass assignments.

1996 saw another large step forward in performance with the introduction of the 5973, which featured a patented gold plated fused silica quadrupole¹ further increasing system stability and robustness as a result of the very low expansion coefficient and ideal electrical properties. This quadrupole forms the basis of Agilent's current GC/MS platforms.



Gold plated fused silica quad from 5973 MSD

1994 – 2001 Benchtop ICP-MS

The HP4500 Series ICP-MS was the first benchtop version of this technique, and introduced capabilities that provided users with a range of options in their analysis. This included a cool plasma mode that expanded the analytical capabilities of the system. The second generation of the benchtop ICP-MS the 7500 was introduced in 2000, increasing the linear dynamic range to 9 orders of magnitude and was enhanced in 2001 with the introduction of a polyatomic interference removal technology the octopole reaction cell "ORS".



4500 Benchtop ICP-MS 7500 ICP-MS

Expanding Technologies Routine, Reliable and Robust for Every Analysis

1997 – 2003 New Benchtop LC/MS Technologies

To complete the portfolio of benchtop MS technologies, HP developed a benchtop single quadrupole LC/MS system, including the new Patented orthogonal electrospray source². This system was followed in 2000 with the introduction of an Ion Trap system, co-developed with Bruker. This allowed a wider range of analytes than before to be covered.



1st Generation benchtop LC/MSD

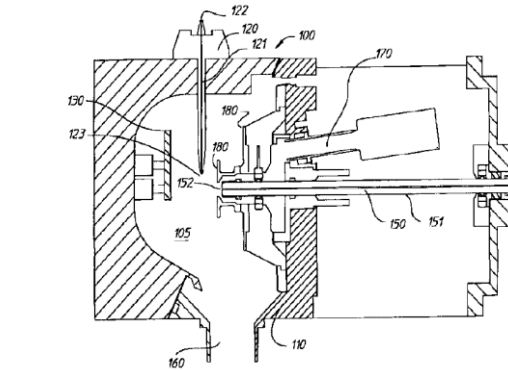

Figure taken from orthogonal spray patent

This period also saw the introduction of improved GC/MS performance though electronic advancements and materials selection

2003 LC Time of Flight (TOF) Systems

After a brief period with a dedicated MALDI-TOF system in the late '90s, 2003 marked the entry of Agilent into the high resolution accurate mass market with the introduction of a benchtop TOF system. This used a INVAR tube for the flight path, minimizing the effect of external thermal changes and offering both good resolution and mass accuracy in a benchtop unit.



First generation benchtop LC/TOF

2006 – 2009 New MS Technologies and Shrinking Products

Agilent continued to invest in the development of new technologies designed to offer users a mass spectrometer that would continue to take the technique from a specialized user, to one in many labs, in the way the 'GC/MSD' systems had done in the '80s. This led to the introduction of both LC Triple quadrupole and Q-TOF technologies in 2006. This was followed with continued improvements and additions to the platforms, increasing performance for a wide range of areas, including sensitivity, source design, resolution and speed of analysis.



6410 LC/TQ system



6510 LC/QTOF system

2006 also saw the reduction in size of the benchtop 6100 LC/MSD, closely followed in 2007 with the 7700 ICP-MS model, minimizing the amount of bench space required without compromising performance, further opening the opportunity for new users to move to MS.



6100 LC/MSD



7700 ICP-MS

GC/MS saw the introduction of the 7000 series triple quadrupole system in 2007, based on the well accepted gold plated quadrupole technology and benchtop design, quickly becoming a leader in the market.

References

- ¹ US Patent#5,616,919
- ² US Patents#5,838,003, 6,278,110

